



MLink User's Guide

Revision – Rev 7

Apr 4, 2016



106, 4715 - 13th St. NE, Calgary, Alberta, Canada, T2E 6M3
(403) 777-9988 support@aurorawirelessnetworks.com

Confidential and Proprietary

Table of Contents

1	LEGAL DISCLAIMER AND CONDITIONS OF USE	2
2	REVISION HISTORY	3
3	ABBREVIATIONS	3
4	REFERENCE DOCUMENTS	3
5	PRODUCT OVERVIEW	3
6	FEATURES	4
7	SPECIFICATIONS	4
7.1	PHYSICAL.....	4
7.2	ELECTRICAL	4
7.3	DATA RATES	4
7.4	INTERFACES.....	5
7.5	FIRMWARE	5
7.6	ENVIRONMENTAL.....	5
8	REGULATORY CERTIFICATION	5
8.1	UNITED STATES (FCC).....	5
8.1.1	<i>Labeling Requirements</i>	5
8.1.2	<i>FCC Notices</i>	6
8.2	CANADA (IC).....	6
8.3	APPROVED ANTENNAS.....	7
9	INTEGRATION INSTRUCTIONS	9
9.1	MOUNTING	9
9.2	INTERFACES.....	10
9.2.1	<i>900 MHz and GPS Antenna</i>	10
9.2.2	<i>900 MHz and GPS RF connector</i>	10
9.2.3	<i>Digital/Baseband</i>	11

1 Legal Disclaimer and Conditions of Use

This document contains information for the Aurora MLink 900 Transceiver and accompanying accessories (“Product”) and is provided “as is”. The purpose of providing such information is to enable a Product Developer to understand the Product and how to integrate it into a wireless data solution. Reasonable effort has been made to make the information in this document reliable and consistent with specifications, test measurements and other information. However, Aurora Wireless Networks Inc. and its affiliated companies, directors, officers, employees, agents, trustees or consultants (“Aurora”) assume no responsibility for any typographical, technical, content or other inaccuracies in this document. Aurora reserves the right in its sole discretion and without notice to you to change Product specifications and materials and/or revise this document or withdraw it at any time. The Product Developer assumes the full risk of using the Product specifications and any other information provided.

Your use of the information contained in this Guide is restricted to the development activity authorized under the agreement(s) between you and Aurora, and is otherwise subject to all applicable terms and conditions of such agreement(s), including without limitation software license, warranty, conditions of use and confidentiality provisions.



2 Revision History

Revision	Date	Description
Draft	Feb 10, 2014	Initial release
Rev 1	Feb 27, 2014	Added integration instructions
Rev 2	May 2, 2014	Grammatical & text clean up
Rev 3	May 11, 2014	Added coaxial cable specifications for use with Yagi Antenna
Rev 4	May 12, 2014	Updated the requirements for the external antenna.
Rev 5	May 14, 2014	Updated the integration instructions.
Rev 6	Nov 3, 2014	Updated mechanical drawings
Rev 7	Apr 4, 2016	Minor edits.

3 Abbreviations

Abbreviation	Description
dB	decibel
dBi	decibel relative to an isotropic antenna
dBm	decibel relative to 1 milliwatt
FCC	federal communications commission
FHSS	frequency hopping spread spectrum
GPS	global positioning system
IC	Industry Canada
ISM	industrial, scientific and medical
LCD	liquid crystal display
LED	light emitting diode
LNA	low noise amplifier
PA	power amplifier
PLL	phase locked loop
ppm	parts per million
RF	radio frequency
TDD	Time division duplex
UART	universal asynchronous receiver/transmitter

4 Reference Documents

1. MLink Modem Interface Control – Rev 10, Mar 26, 2016

5 Product Overview

MLink 900 is an ultra energy and cost efficient, long range wireless network. Available as a module, development platform or a fully customized product. Perfect for a wide range of applications, this highly versatile platform enables rapid design, development, and deployment of your next generation products.

6 Features

Ultra Low Energy: Up to **10 years** or more from AA batteries or even directly from the sun.

Impressive Range: Up to **10 km** or more using high efficiency integral antennas.

Design Flexibility: Build your application right on the MLink platform or communicate through the embedded serial port.

Integrated GPS

Direct support for a variety of peripherals:

- Displays, accelerometers
- Industrial sensors, audio alerts

Intrinsically safe options available.

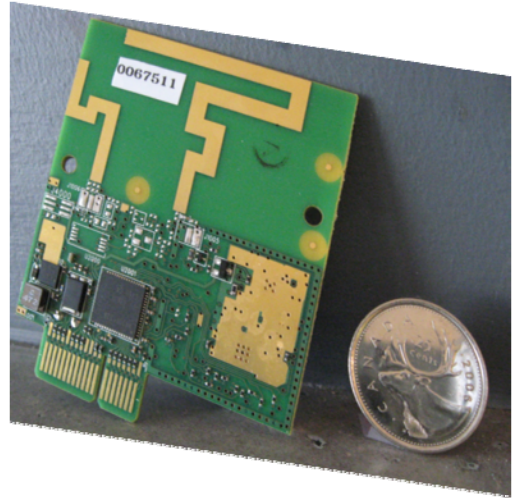

7 Specifications

7.1 Physical

- Size (including antennas) 56 x 64 x 15.25 mm

7.2 Electrical

- Frequency Range
 - 902 - 928 MHz (US/Can)
 - 915 - 928 MHz (AU/NZ)
 - 863 - 868 MHz (Europe) (Anticipated)
- Output Power up to +29 dBm (US/Can)
- Effective Radiated better than -120 dBm
- Sensitivity (1.2 kbps at 10^{-3} BER)
- Access Method TDD - FHSS
- DC Supply Voltage 2.3 to 3.5 Vdc
- Energy Consumption (typical @ 38.4 kbps)
 - TX < 20 mJ
 - RX < 0.5 mJ
 - GPS update < 150 mJ typ
 - Standby (/s) < 50 μ W

7.3 Data Rates

- Dynamically adaptable from 1.2 – 38.4 kbps
- Up to 76.8 kbps optional

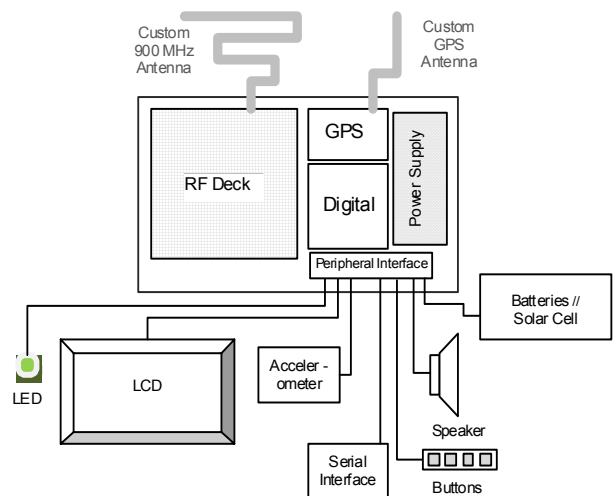

7.4 Interfaces

- RF
 - 50 Ω Radio/GPS
- Digital/Base Band
 - ADC, PWM, GPIO, I2C, SPI, UART
 - 40 pin edge connector

7.5 Firmware

- Real Time Operating System
- Embedded, autonomous protocol
- Up to 32 kB Flash and 4 kB RAM available for customer applications

7.6 Environmental

- Operating Temperature -55 to +85 C
- Storage Temperature -55 to +85 C
- Operating Relative Humidity 0 to 90% non-condensing

8 Regulatory Certification

8.1 United States (FCC)

MLink 900 module meets Part 15 of the FCC rules and regulations. Compliance with the labeling requirements, FCC notices is required. In order to comply with FCC Certification requirements, the Original Equipment Manufacturer (OEM) must fulfill the following requirements.

1. The system integrator must place an exterior label on the outside of the final product housing the MLink 900 Module. Figure 8.1.1.1 below shows the contents that must be included in this label.
2. MLink 900 modules may only be used with the antenna that has been tested and approved for use with the module.
3. NOTE: AURORA WIRELESS NETWORKS LTD IS NOT RESPONSIBLE FOR ANY CHANGES OR MODIFICATIONS NOT EXPRESSLY APPROVED BY THE PARTY RESPONSIBLE FOR COMPLIANCE. SUCH MODIFICATIONS COULD VOID THE USER'S AUTHORITY TO OPERATE THE EQUIPMENT.

8.1.1 Labeling Requirements

The OEM must make sure that FCC labeling requirements are met. This includes a clearly visible exterior label on the outside of the final product housing that displays the contents shown in Figure 8.1.1.1 below.

Manufacturer's name Brand name or Trade Name
Contains MLink 900 FCC ID: KQNMLINK900 IC ID: 2361A-MLINK900
This device complies with Part 15 of the FCC Rules. Operation is subject to the following two conditions: (1) This device may not cause harmful interference, and (2) this device must accept any interference received, including interference that may cause undesired operation.

Figure 8.1.1.1 – FCC Label

8.1.2 FCC Notices

WARNING: The MLink 900 modules have been tested by the FCC for use with other products without further certification (as per FCC Section 2.1091). Changes or modifications to this device not expressly approved by Aurora Wireless Networks could void the user's authority to operate the equipment.

NOTICE: OEM's must verify the final end product complies with unintentional radiators (FCC Section 15.107 and 15.109) before providing a declaration of conformity for their final product to Part 15 of the FCC Rules.

NOTICE: The MLink 900 modules have been certified for mobile and fixed radio applications. If the module will be used for portable applications, the device must undergo SAR testing.

RF Exposure WARNING: This equipment complies with FCC radiation exposure limits set forth for an uncontrolled environment. This equipment should be installed and operated with minimum distance 20 cm between the radiator and your body. This transmitter must not be co-located or operating in conjunction with any other antenna or transmitter.

NOTICE: The preceding statement must be included as a CAUTION statement in OEM product manuals in order to alert users of FCC RF Exposure compliance.

8.2 Canada (IC)

This device complies with Industry Canada license-exempt RSS standard(s). Operation is subject to the following two conditions: (1) this device may not cause interference, and (2) this device must accept any interference, including interference that may cause undesired operation of the device.

Le présent appareil est conforme aux CNR d'Industrie Canada applicables aux appareils radio exempts de licence. L'exploitation est autorisée aux deux conditions suivantes : (1) l'appareil ne doit pas produire de brouillage, et (2) l'utilisateur de l'appareil doit accepter tout brouillage radioélectrique subi, même si le brouillage est susceptible d'en compromettre le fonctionnement.

Under Industry Canada regulations, this radio transmitter may only operate using an antenna of a type and maximum (or lesser) gain approved for the transmitter by Industry Canada. To reduce potential radio interference to other users, the antenna type and its gain should be so chosen that the equivalent isotropically radiated power (e.i.r.p.) is not more than that necessary for successful communication.

Conformément à la réglementation d'Industrie Canada, le présent émetteur radio peut fonctionner avec une antenne d'un type et d'un gain maximal (ou inférieur) approuvé pour l'émetteur par Industrie Canada. Dans le but de réduire les risques de brouillage radioélectrique à l'intention des autres utilisateurs, il faut choisir le type d'antenne et son gain de sorte que la puissance isotrope rayonnée équivalente (p.i.r.e.) ne dépasse pas l'intensité nécessaire à l'établissement d'une communication satisfaisante.

This radio transmitter Model: MLink 900, IC: 2361A–MLINK900 has been approved by Industry Canada to operate with the antenna types listed below with the maximum permissible gain and required antenna impedance for each antenna type indicated. Antenna types not included in this list, having a gain greater than the maximum gain indicated for that type, are strictly prohibited for use with this device.

Le présent émetteur radio Model: MLink 900, IC: 2361A – MLINK900 a été approuvé par Industrie Canada pour fonctionner avec les types d'antenne énumérés ci-dessous et ayant un gain admissible maximal et l'impédance requise pour chaque type d'antenne. Les types d'antenne non inclus dans cette liste, ou dont le gain est supérieur au gain maximal indiqué, sont strictement interdits pour l'exploitation de l'émetteur.

8.3 Approved Antennas

MLink 900 modules are approved for mobile and fixed applications. FCC & IC requires that for mobile applications the antenna be mounted a minimum of 20 cm from users, as captured in section 8.1.2 above.

MLink 900 modules has been approved for use with both an integral antenna and recommended external antenna captured below including a 1.2 dB min cable loss. External antenna types with the same or **lower** maximum gain are permitted for use with MLink 900. Professional installation is required for the external antenna.

Manufacturer	Part Number	Type	Gain	Application	Min Separation
MaxStream Inc or Laird Technologies	A09-Y8NF or PC904	4 Element Yagi	4.8 dBd ¹	Mobile and Fixed	20 cm

Note 1: Including 1.2 dB min cable loss as captured below:

- 5 ft min of RG-174 (27.9 dB/100 ft @ 900 MHz)
- 7 ft min of RG-58/RG-8X (20.1 dB/100 ft @ 900 MHz)
- 16 ft min of RG-213/LMR240 (7.7 dB/100 ft @ 900 MHz)
- 32 ft min of LMR-400 (3.9 dB/100 ft @ 900 MHz)

Part Number	A09-Y8NF
Photo	
Specific Freq. (MHz)	896-980
Gain (dBd)	6 ²
Maximum Power Input (Watts)	200
Product Narrative	4 element, 6 dB gain yagi. 1 piece unit construction with elements welded to boom. Feed system is enclosed in potted PVC radome for weatherability.
Type	4-Element Yagi
General Freq. (MHz)	896-980
Bandwidth @ Rated VSWR (MHz)	84
Gain (dBi)	8.15 ³
H. Beamwidth	105 Deg.
Vert. Beamwidth	65 Deg.
Front to Back Ratio (dB)	16 dB
VSWR	1.5:1
Polarization	Vert./Horiz.
Lightning Prot.	DC Ground
Size (HxWxD")	12"
Weight	0.68

Note 2: With 1.2 dB min cable loss (as captured below) for 4.8 dBd total.

Note 3: With 1.2 dB min cable loss (as captured below) for 7 dBi total.

- 5 ft min of RG-174 (27.9 dB/100 ft @ 900 MHz)
- 7 ft min of RG-58/RG-8X (20.1 dB/100 ft @ 900 MHz)
- 16 ft min of RG-213/LMR240 (7.7 dB/100 ft @ 900 MHz)
- 32 ft min of LMR-400 (3.9 dB/100 ft @ 900 MHz)

9 Integration Instructions

MLink 900 is designed for use in countless wireless applications requiring long range communications with low energy consumption. To ensure that the final product complies with the all of the regulatory requirements for the Modular Grant the following integration instructions should be followed. MLink is limited to OEM installation ONLY. The OEM integrator is responsible for ensuring that the end-user has no manual instructions to remove or install the module.

9.1 Mounting

Two mounting holes are provided as shown in the figure below. In addition MLink incorporates an edge connector which mates with a Samtec MEC1-120-02-S-D-A connector. These can be used to securely mount MLink in the final product.

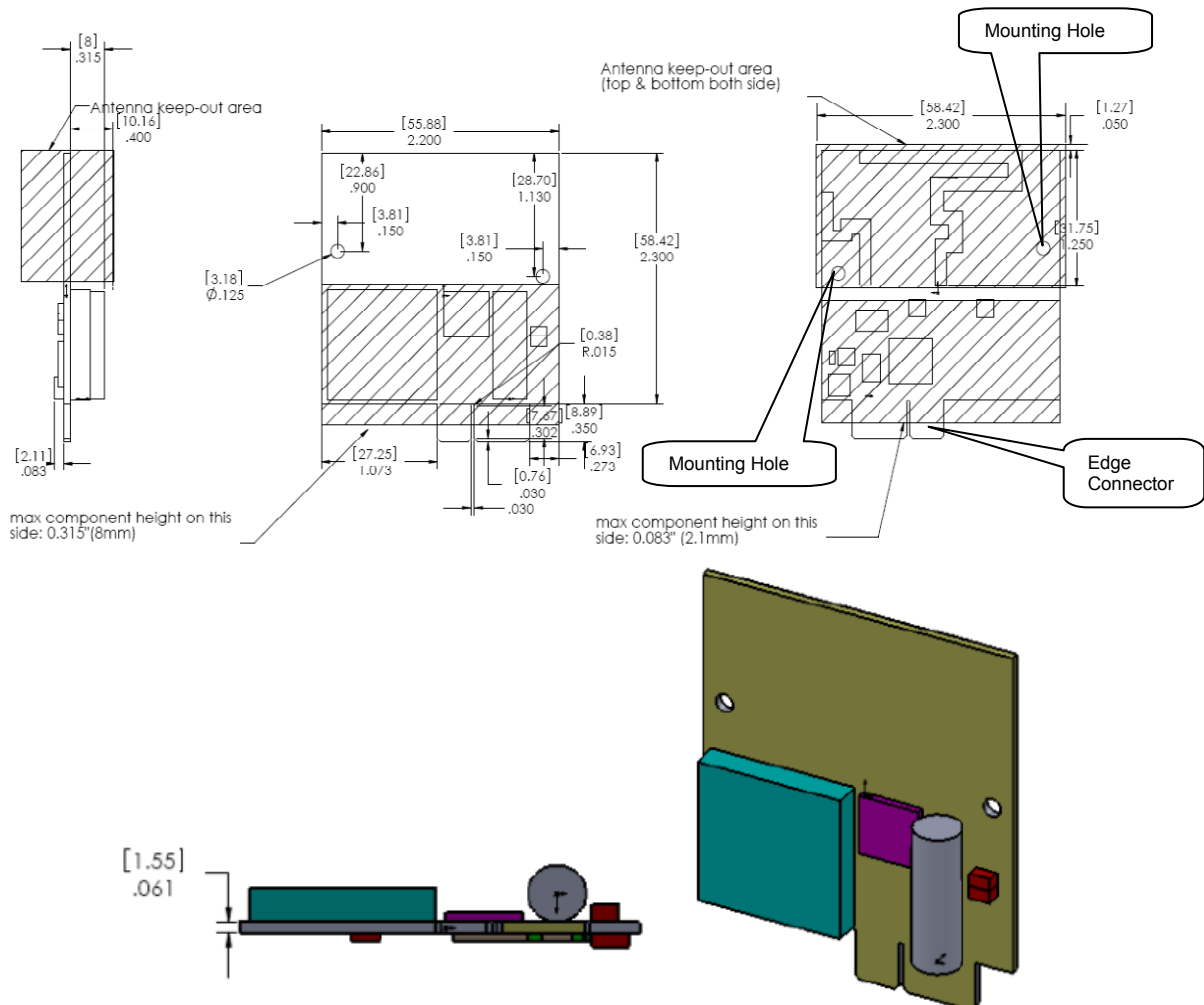

Figure 9.1.1 – MLink 900 Mechanical Drawing with Integral Antennas

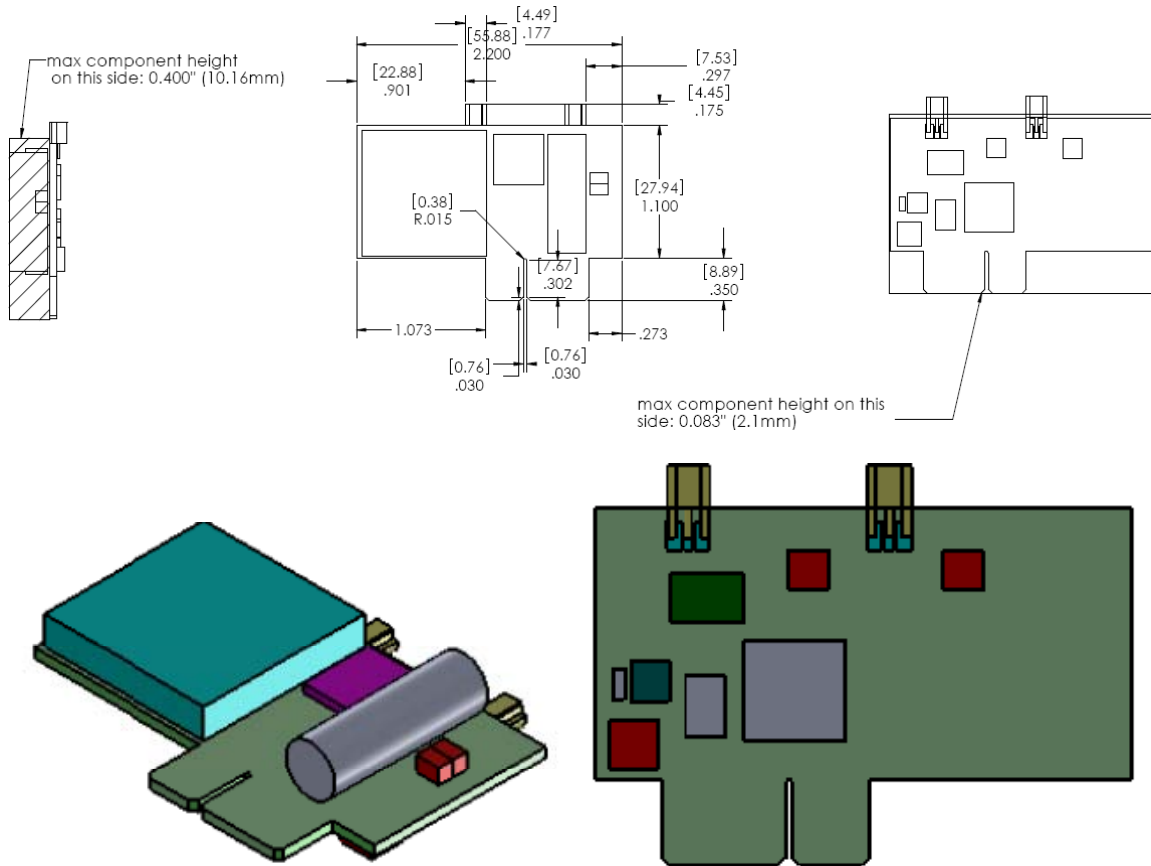

Figure 9.1.2 – MLink 900 Mechanical Drawing with MMCX Antenna Connectors

9.2 Interfaces

There are three interfaces on the MLink 900 modules - 900 MHz Antenna/RF, GPS Antenna/RF and Digital/Baseband.

9.2.1 900 MHz and GPS Antenna

For the MLink 900A modules integral 900 MHz and GPS antennas are incorporated. These antennas have been design to handle a wide variety of environments. To minimize degradation in the performance of the antennas it is recommended that non metallic, low dielectric constant, low dielectric loss materials such as the housing ideally be 0.25" or greater from the antennas (as showing in figure 9.1.1).

Note: As per section 8.1.2 a minimum 8" (20 cm) separation must be maintained between the 900 MHz antenna and the user to ensure compliance with the MPE regulatory requirements. Otherwise additional regulatory approval may be required for the final product.

9.2.2 900 MHz and GPS RF connector

For the MLink 900C modules RF connections to both the 900 MHz and GPS are provided to permit external antennas to be used which can be mounted remotely from MLink:

900 MHz

Impedance:	50 Ω
Connector:	MMCX female jack
Antenna:	See section 8.1.3 ^{1,2}

Note 1: Similar antennas with the same or lower gain may be used.

Note 2: As per section 8.1.2 a minimum 20 cm separation must be maintained between the 900 MHz antenna and the user to ensure compliance with the MPE regulatory requirements. Otherwise additional regulatory approval may be required for the final product. Professional installation is required for the external antenna.

GPS

Impedance:	50 Ω
Connector:	MMCX female jack
Antenna:	Active GPS antenna with built in LNA
DC Power:	3 V 50 mA max

9.2.3 Digital/Baseband

MLink 900 incorporates a standard edge connector which mates with a Samtec MEC1-120-02-S-D-A connector in the final product. Power and standard digital interfaces to LED's, Buzzers, Sensors are provided. Many of the interface pins are reconfigurable and a list of key pins are

Pin #	Name	Description
39	Vcc (input)	Power Supply <ul style="list-style-type: none"> Main power supply for MLink Typically provided by two AA, C, or D cell batteries 2.2 to 3.3 Vdc 500 mA max current draw
31, 32	Ground (bi-directional)	Ground <ul style="list-style-type: none"> Low impedance ground connection for MLink power supply, digital and analog signals.
10, 12	UART1 (bi-directional)	Digital (see note 1) <ul style="list-style-type: none"> GPS serial interface
21, 23	UART2 (bi-directional)	Digital (see note 1) <ul style="list-style-type: none"> MLink serial interface
18	P1PPs (output)	GPS 1pps
8, 10, 12, 26, 22, 28, 30, 34	Digital I/O (bi-directional)	Digital (see note 1) <ul style="list-style-type: none"> General purpose digital I/O which is firmware configurable – for example for use with LED, Buttons
4	Analog Input (input)	Analog <ul style="list-style-type: none"> A/D used to sample analog voltage – i.e. sensor output. 0 to 1.5 V 10 kohms min input impedance

Note 1: Digital levels for operation.

Input:

- @ $V_{DD} = 2.2\text{ V}$, max low level 1.0 V.
- @ $V_{DD} = 3.3\text{ V}$, max low level 1.65 V.
- @ $V_{DD} = 2.2\text{ V}$, min high level 1.2 V.
- @ $V_{DD} = 3.3\text{ V}$, min high level 1.8 V.

Min input impedance 20k Ω
Max input capacitance 10 pF

Output:

- @ $V_{DD} = 2.2\text{ V}$, max low level 0.25 V.
 - @ $V_{DD} = 3.3\text{ V}$, max low level 0.25 V.
 - @ $V_{DD} = 2.2\text{ V}$, min high level 1.95 V.
 - @ $V_{DD} = 3.3\text{ V}$, min high level 3.05 V.
- Max output impedance 500 Ω
Max output capacitance 10 pF

For additional information please contact Aurora Wireless Networks at 403-777-9988 or support@aurorawirelessnetworks.com.